

Shuttle Valve Design

Team #17

Date

December 3rd, 2013

Group Members

Ryan Laney – Team Leader

Billy Ernst – Team Webmaster

Samantha Zeidel – Team Treasurer

Instructor

Dr. Kamal Amin

Sponsor

Verdicorp Inc.
Robert Parsons



Faculty Advisor

Dr. Steven Van Sciver



Project Overview

- Verdicorp Environmental Technologies has developed a revolutionary Organic Rankine Cycle (ORC)
- ORC uses waste heat from a low grade source and converts it to useful power
- The ORC systems have somewhat low efficiency (~10-14%); Special concern within the company to maximize this efficiency in any way possible
- ORC is cable of producing ~125 kW
- Parasitic losses consume ~20 kW
(Pump ~10 kW)
- Senior Design Team 17 has been tasked with increasing the efficiency of the system
(Removal and replacement of the pump)

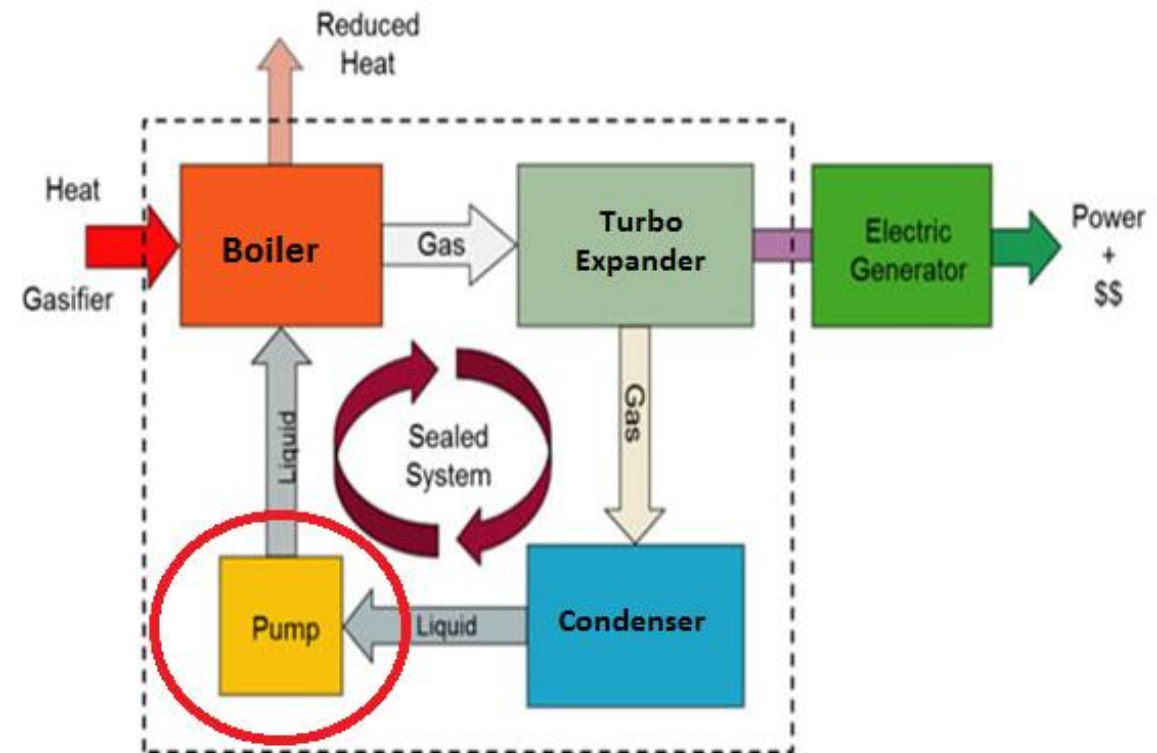

Presented by: Ryan Laney

Project Objectives

- Design a shuttle valve system to replace the pump within the ORC
- Maintain the continuous flow of liquid within the ORC (~ 3 gpm)
- Use solenoid valves with the aid of gravity to adjust the pressure inside the vessels
- Transfer the liquid in the system from the low pressure side to the high pressure side
- Minimize the parasitic losses in the system (electrical consumption)
- Confirm on a final design concept by late-October 2013
- Order/purchase all components and materials by December 2013
- Construct a prototype of the final design during Spring 2014



Fall Semester Gantt Chart

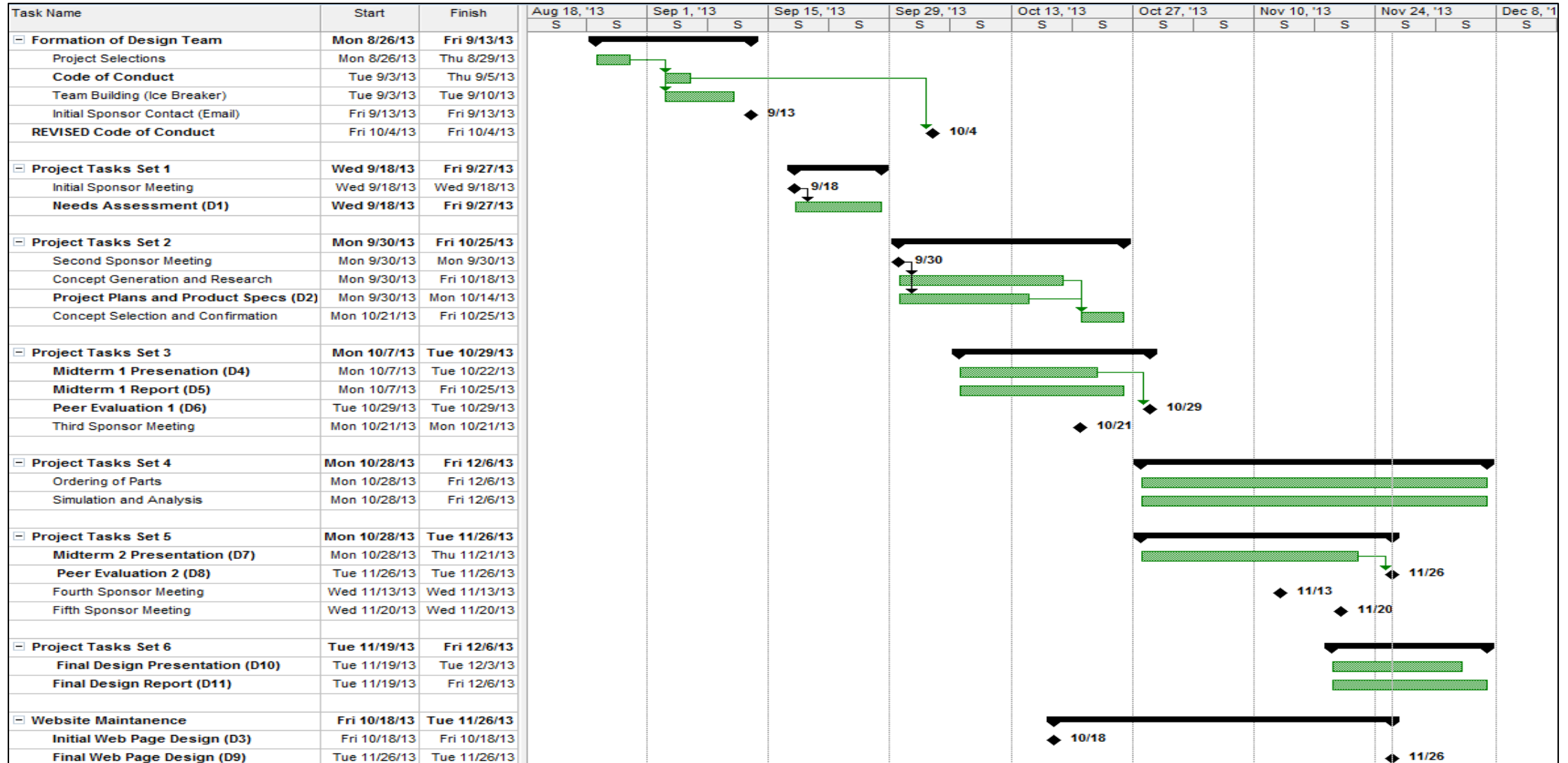

Presented by: Ryan Laney

Final Design Concept

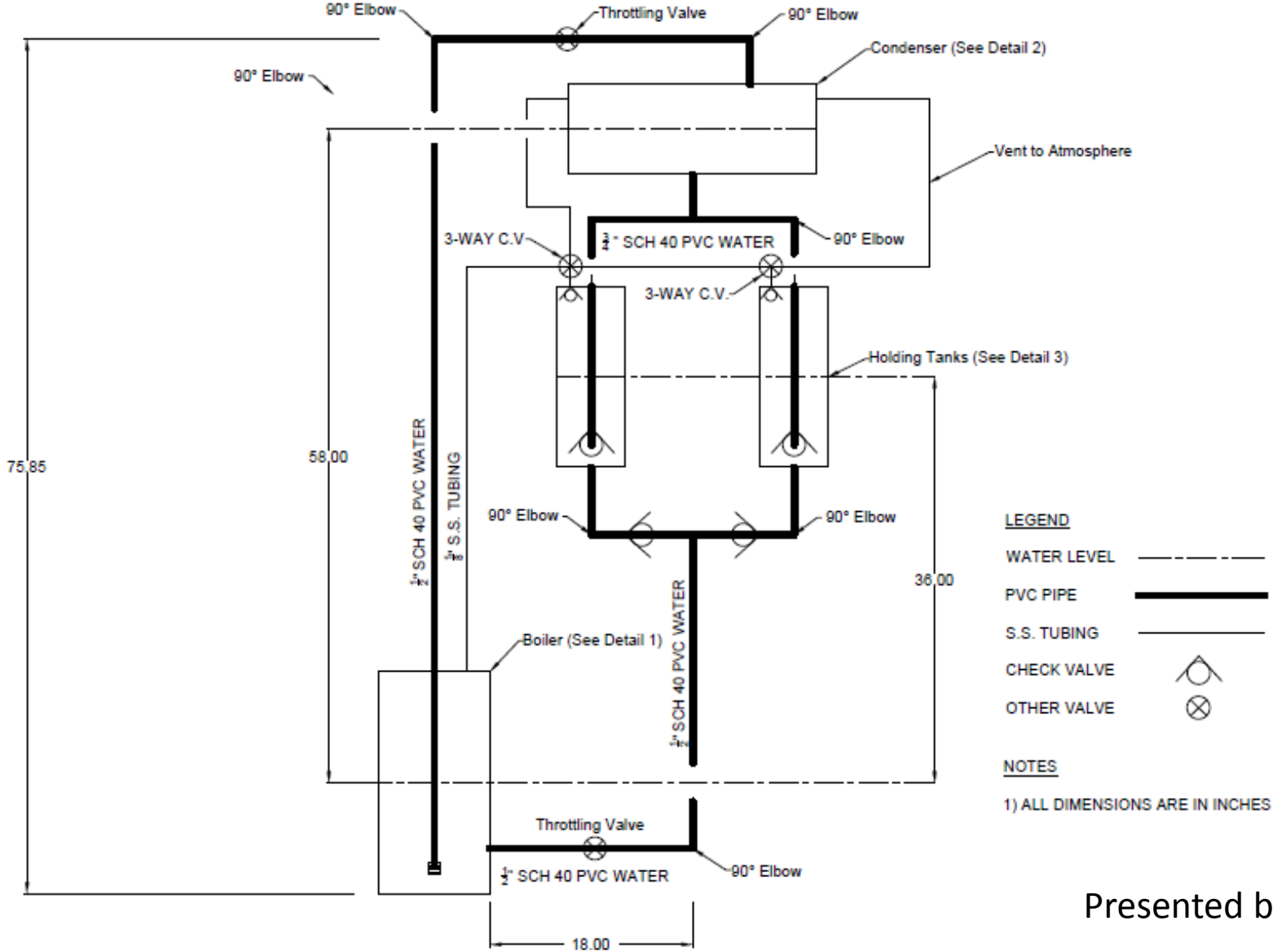

Presented by: Billy Ernst

Final Design Concept

- Execution of Holding Tank 1

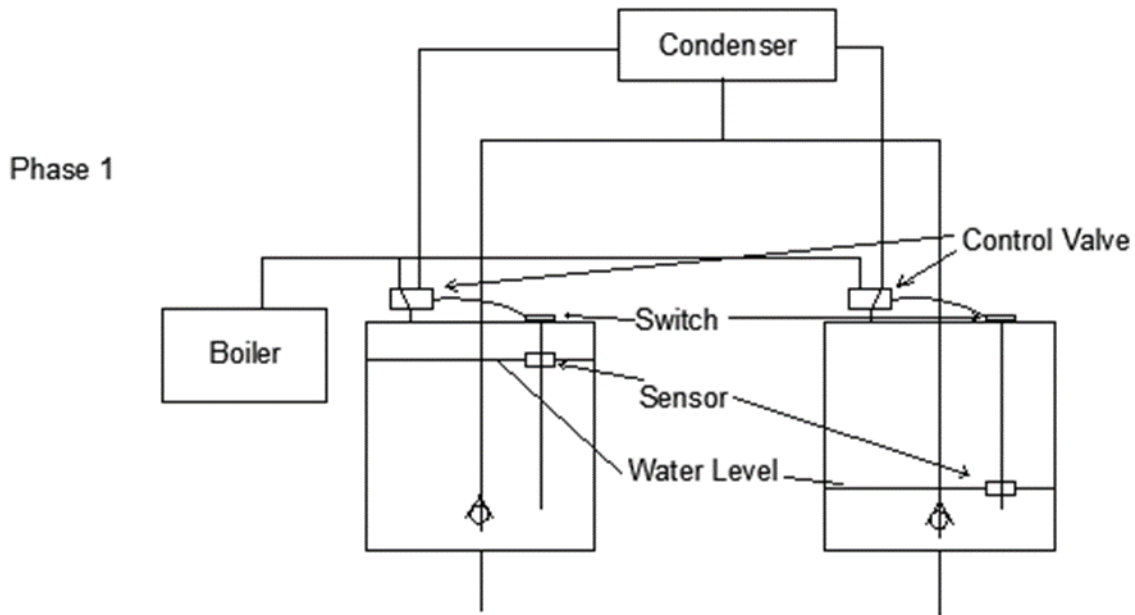

- Execution of Holding Tank 2

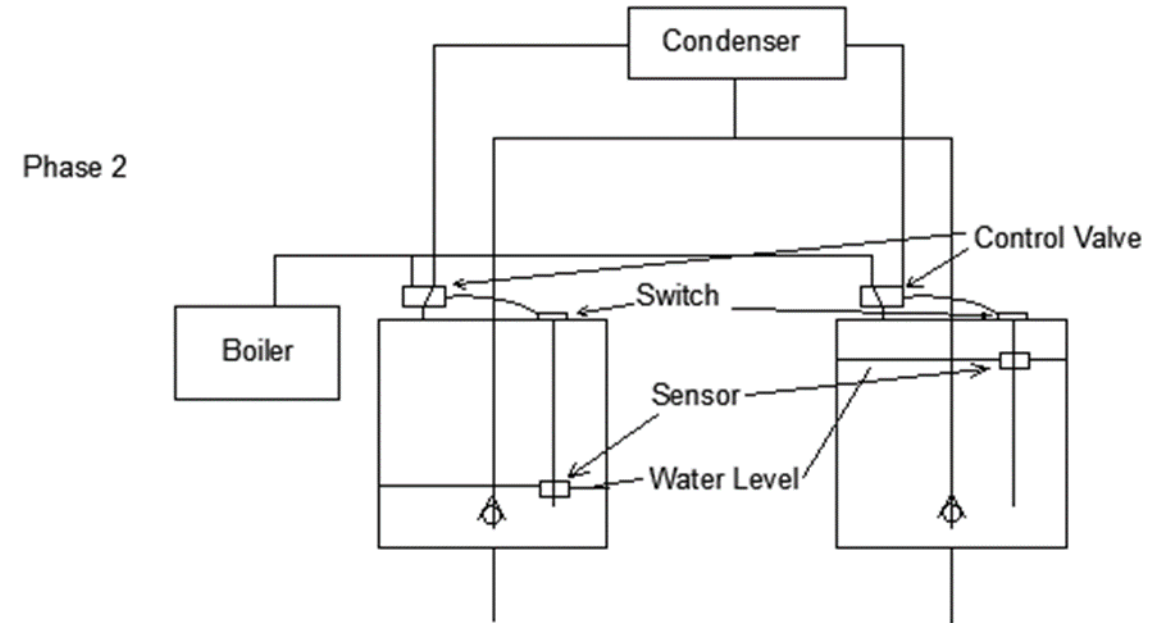

Relevant Equations for Pipe Flows

- *Modified Bernoulli Equation*

- $$\frac{p_1}{\rho g} + \frac{V_1^2}{2g} + z_1 = \frac{p_2}{\rho g} + \frac{V_2^2}{2g} + z_2 + \frac{fLV^2}{D2g} + \sum K \frac{V^2}{2g}$$

- $$\Delta P_L = \frac{\left(\frac{fL}{D} + K_t\right)V^2}{2g}$$

- $\frac{fL}{D}$ term applies to friction in piping
- K term applies to minor losses in fittings



Daniel Bernoulli – Bernoulli Principle

PIPE-FLO Software Calculations

- **Boiler to Condenser**

- dZ = 58 in. (Hydrostatic Head)
- Minor Losses (Two 90° Elbows) – Major losses (L = 72 in.)
- With an internal pressure in the boiler of 50 psi and using ½” PVC, the flow rate will be 39.04 GPM
- A throttling valve will be used to model the turbo expander and provide the pressure drop and decrease the flow rate to the required 3 GPM

EngineeredSoftware, Inc.

PIPE FLO

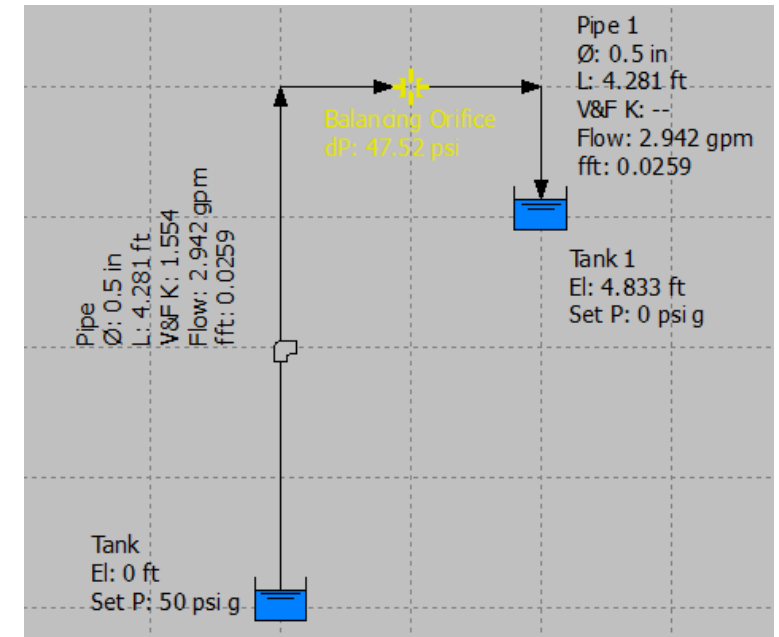

Presented by: Billy Ernst

PIPE-FLO Software Calculations

- **Condenser to Holding Tanks**
 - Flow rate will be gravity driven
 - $dZ = 22$ in. (Hydrostatic Head)
 - Minor Losses (One 90° Elbow, 1 Tee, One Check-Valve) (To each tank)
- Using 1/2" PVC, GPM (max) = 2.86 GPM
(Not sufficient for design flow rate of 3 GPM)
- Using 3/4" PVC, GPM (max) = 5.33 GPM
Therefore 3/4" PVC must be used

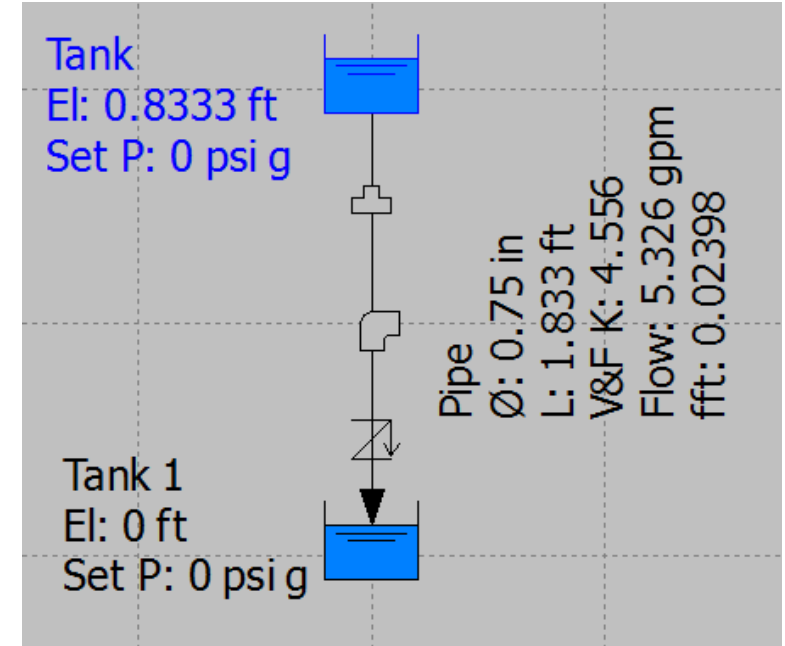

PIPE-FLO Software Calculations

- **Holding Tanks to Boiler**

- Flow rate will be gravity driven
- $dZ = 36$ in. (Hydrostatic Head)
- Minor Losses (Two 90° Elbows, 1 Tee, One Check Valve)(To each tank)
- Using 1/2" PVC, GPM (max) = 4.22 GPM

Therefore 1/2" PVC must be used along with a throttling valve to restrict the flow down to 3 GPM

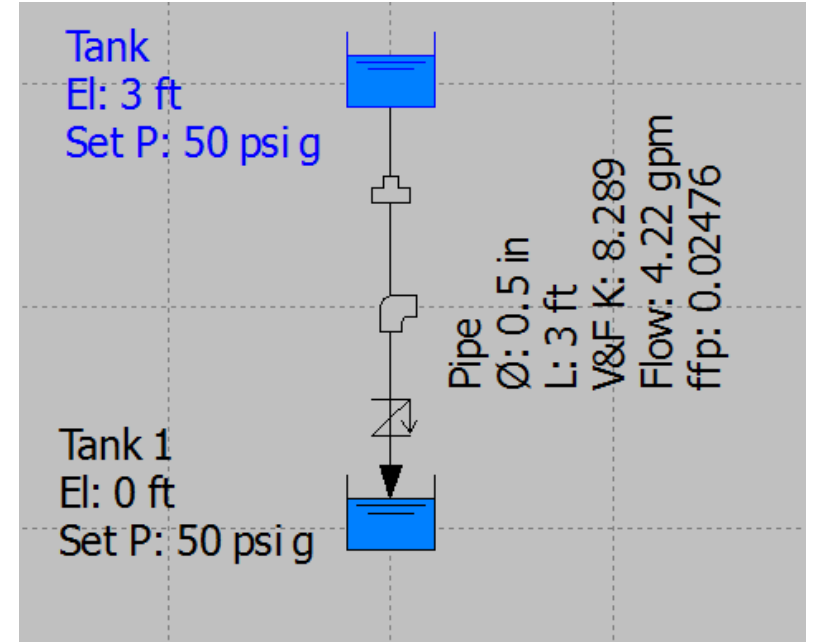

Components of Design

- **Boiler**

- Pittsburgh Automotive 6.25 Gallon Oil Extractor
- Pressurized vessel in our system (50 psi)



- **Condenser (Changed)**

- Ace / DenHartog 3 Gallon Rectangular Specialty Rinse Tank
- Changed = 5 Gallon Tank has 8-10 week lead time
- Thickness: 1/4 in. (Allowing for modifications)
- Non-pressurized vessel in our system

- **Holding Tanks**

- 6 in. Acrylic Tubes (Walls)
- 2 – 3 in. Acrylic Sheet (End Caps)
- Needs to be constructed by the team
- Pressurized vessel in our system (50 psi)



Manufacturing/Machining Approaches

- **Boiler**

- All modifications will be done at Verdicorp machine shop
- Top of oil extractor must be modified
- Components must be removed to insert 1/2 in. PVC and two 1/8 in. Stainless Steel tubing
- Bottom of tank must be modified to insert 1/2 in. PVC from holding tanks

- **Condenser**

- All modifications will be done at Verdicorp machine shop
- Holes must be cut into top and bottom of condenser for pipe inlets/outlets

- **Holding tanks**

- Will be made from 6 in. Acrylic tubes (Walls) and 2-3 in. Acrylic sheet (End Caps)
- Top and Bottom end caps will be threaded and attached to the ends of the tubes
- All holes for valves and switches will be drilled and threaded by machinist at Verdicorp

Components of Design

- **Control Valves**

- Parker Pneumatic Single Solenoid, 3-way, 2-position, NC
- Air Control Valve; Port Size: 1/8 in. NPT
- Voltage: 24 VDC



- **Sensor (Possibly Changing)**

- Gems LS-300 Series Multi-Point Level Switch
- Simple and efficient way of monitoring water levels
- Very expensive due to customization
- Other Float Switch Sensors are being explored

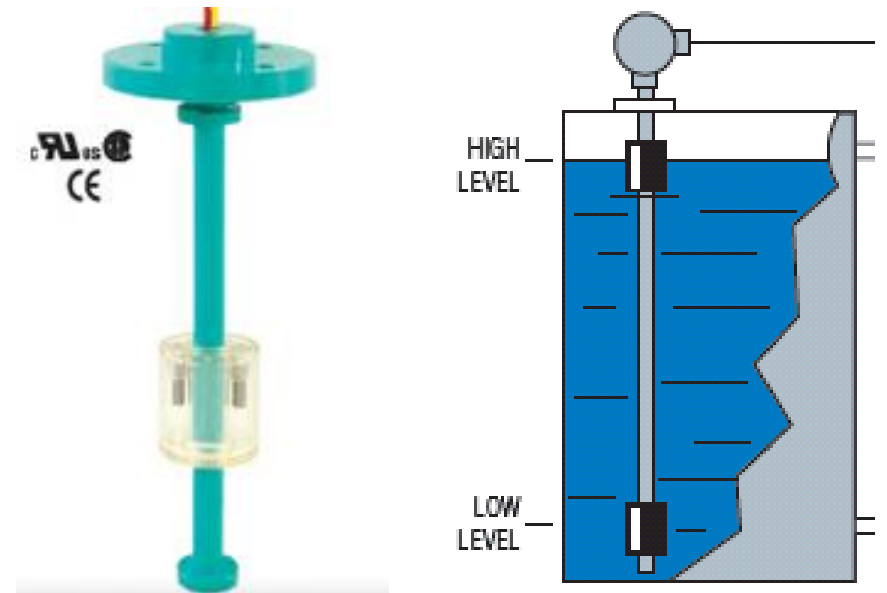

- **Relay**

- Provided by Verdicorp
- Voltage: 24 VDC (Control Valve voltage)

Components of Design

- **Piping**

- **Water Pipes:** 1/2 in. and 3/4 in. PVC Schedule 40
- **Pressure Pipes:** 1/8 in. Stainless Steel Tubing

- **Throttle Valves (Plug Valves?)**

- Homewerks Worldwide 1/2 in. Brass FPTxFPT Gate Valve
- Threaded connection, Max Pressure = 125 psi

- **Check Valves**

- Homewerks Worldwide 1/2 in. and 3/4 in. Lead Free Brass FPTxFPT Swing Check Valve
- 1/8 in. Ingersoll-Rand/Aro NPT Check Valve
- Threaded connection, Max Pressure = 200 psi

- **Pipe Fittings**

- Mueller Streamline 1/2 in. and 3/4 in. PVC SCH 40 SxS 90° Elbow
- Mueller Streamline 1/2 in. and 3/4 in. PVC SCH 40 SxSxS Tee

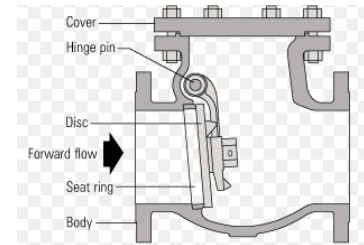
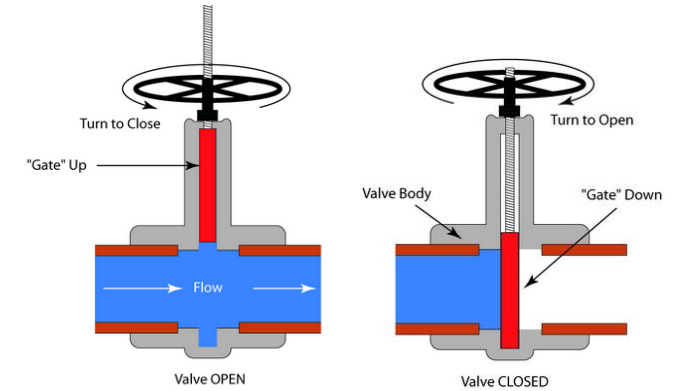

Environment and Safety

- ORC Environmental benefits
 - Reduces the amount of CO₂ emissions
 - Refrigerant 245fa is non-flammable and long-lasting
- Safety Risks
 - Irritation with eye contact
 - Dizziness and increased heart rate if inhaled
 - Testing and calculations will be done with water and compressed air



Project Procurement (By December 6th)

Part #	Component	Product Description	Quantity	Vendor	List Price (Each)	Status
1	Heat Exchanger	6.25 Gallon Oil Extractor	1	Harbor Freight Tools	\$134.99	Received
2	Condenser	Ace / DenHartog 3 Gallon Rectangular Specialty Rinse Tank	1	The Tank Depot (Online)	\$33.99	Ordered
3	Holding Tanks	6" Acrylic Tubing (Walls) 2-3" Acrylic Sheet (End Caps)	2	N/A	N/A	Pending
4	Throttle Valve 1	1/2" Brass FBTxFBT Gate Valve	2	The Home Depot	\$6.35	Received
5	Throttle Valve 2	3/4" Brass FBTxFBT Gate Valve (Possible Inclusion – Pending)	1	The Home Depot	\$7.73	Received
6	Check Valve 1	1/2" Lead Free Brass FPTxFPT Swing Check Valve	2	The Home Depot	\$7.02	Received
7	Check Valve 2	3/4" Lead Free Brass FPTxFPT Swing Check Valve	2	The Home Depot	\$9.41	Received
8	Check Valve 3	1/8" INGERSOLL-RAND/ARO NPT Check Valve	2	Grainger Industrial Supply	\$18.97	Received
9	Control Valve	Parker Air Control Valve Single Solenoid, 3-way, 2-pos, 1/8" NPT	2	Global Industrial (Online)	\$51.95	Ordered
10	Sensor	LS-300 Series Multi-Point Level Switch	2	Gems Sensors & Controls (Online)	\$163.60	Pending

Presented by: Ryan Laney

Project Procurement (By December 6th)

Part #	Component	Product Description	Quantity	Vendor	List Price (Each)	Status
11	Relay	Provided by Verdicorp	2	Verdicorp	\$0	Received
12	Pressure Line	1/8" x 6' Stainless Steel Tubing	~11 ft.	Grainger Industrial Supply	\$23.70	Ordered
13	Water Pipe 1	1/2" x 10' PVC Schedule 40 Plain-End Pipe	~16 ft.	The Home Depot	\$1.81	Received
14	Water Pipe 2	3/4" x 10' PVC Schedule 40 Plain-End Pipe	~6 ft.	The Home Depot	\$2.28	Received
15	Water Pipe Elbow 1	1/2" PVC Pipe 90° Elbow	5	The Home Depot	\$0.46	Received
16	Water Pipe Elbow 2	3/4" PVC Pipe 90° Elbow	2	The Home Depot	\$0.46	Received
17	Water Pipe Tee 1	1/2" PVC Pipe Tee	1	The Home Depot	\$0.47	Received
18	Water Pipe Tee 2	3/4" PVC Pipe Tee	1	The Home Depot	\$0.47	Received
19	Air Compressor	Porter-Cable 3.5 Gallon 135 psi Pancake Compressor	1	The Home Depot (Online)	\$99.88	Ordered

Presented by: Ryan Laney

Financial Analysis

- Overall Budget: \$2000
- Estimated Expenditure (so far): \$840.92
 - Excludes tax on items; Excludes shipping and handling
 - Piping Components (Pipes, Standard Valves, Fittings): \$140.96
 - Components (Boiler, Condenser, Control Valves, Relay, Air Compressor): \$372.76
 - **Sensors: \$163.60 (each) = \$327.20**
 - **NOT INCLUDED: Acrylic Material for Holding Tanks = \$\$\$**
- Analysis of cost savings for implementation into the actual ORC to be included in final report



Project Summary

- Final Design
 - Final design concept has been finalized
 - Modifications may need to be made after prototyping and testing has been completed
- Project Components
 - Almost all components have been selected and will be used pending that the prototype works sufficiently during testing
 - All components will be purchased/ordered before the end of this week



Future Plans for January 2014

- All components and materials for the prototype should be received
- Construct and machine parts and components that require modification
- Start building and testing individual portions of the system
- Begin construction of the entire prototype
- Analyze the operation of the prototype and make any warranted improvements



Any Questions??

Presented by: Ryan Laney